



# TECHNICAL SERVICE MANUAL

HEAVY-DUTY PUMPS

SERIES 4195

SIZES KE, KKE, LQE, LSE, Q, & QS

SECTION	TSM 144.1
PAGE	1 OF 10
ISSUE	B

## CONTENTS

Introduction . . . . .	1
Safety Information. . . . .	2
Special Information . . . . .	3
Special Mechanical Seals. . . . .	3
Maintenance . . . . .	3
Disassembly . . . . .	4
Assembly . . . . .	7
Thrust Bearing Adjustment . . . . .	8
Installation of Carbon Graphite Bushings . . . . .	8
Pressure Relief Valve Instructions . . . . .	9

UNMOUNTED PUMP	UNITS
Flange & Foot Mounted	Units are designated by the unmounted pump model numbers followed by a letter(s) indicating drive style. D = Direct Drive M = Horizontal Direct Drive R = Reducer Drive
KE4195    LQE4195 KKE4195    LSE4195	
Foot Mounted	D = Direct Drive R = Reducer Drive
Q4195    QS4195	

## INTRODUCTION

The illustrations used in this manual are for identification purposes only and cannot be used for ordering parts. Obtain a parts list from the factory or a Viking® representative. Always give complete name of part, part number and material with model number and serial number of pump when ordering repair parts. The unmounted pump or pump unit model number and serial number are on the nameplate.

In the Viking model number system, basic size letters are combined with series number (4195) are used to indicate either an unmounted pump or mounted pump unit.

This manual deals only with Series 4195 Heavy Duty Pumps. Refer to Figures 1 through 10 for general configuration and nomenclature used in this manual. Pump specifications and recommendations are listed in Catalog Section 144, Series 4195 and 495 Heavy Duty Pumps.

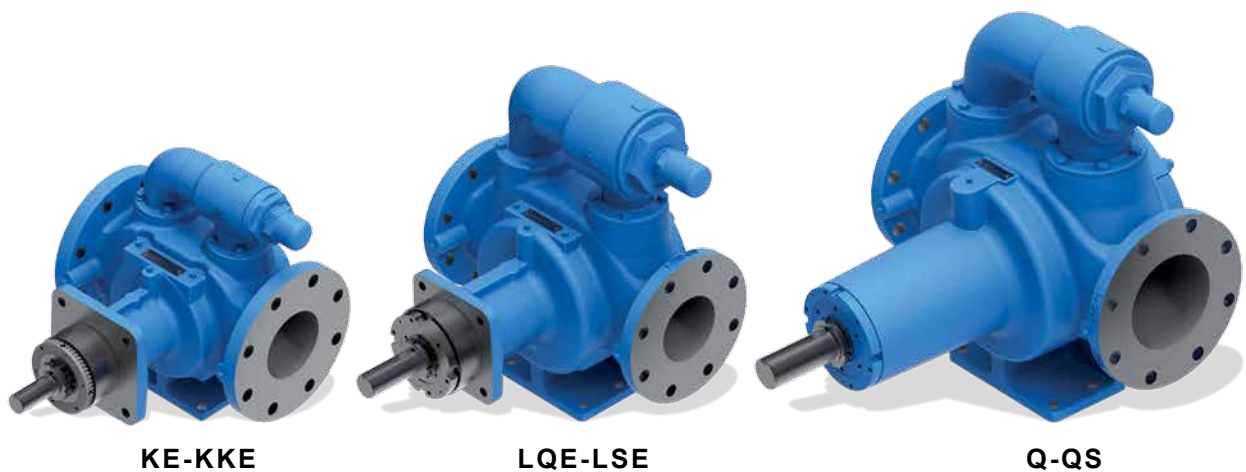

FIGURE 1

KE, KKE, LQE, & LSE 4195 SERIES - Flange & Foot Mounted Unmounted Pumps with Flanged Ports  
Q & QS 4195 SERIES - Foot Mounted Unmounted Pumps with Flanged Ports



# SAFETY INFORMATION AND INSTRUCTIONS

IMPROPER INSTALLATION, OPERATION OR MAINTENANCE OF PUMP MAY CAUSE SERIOUS INJURY OR DEATH AND/OR RESULT IN DAMAGE TO PUMP AND/OR OTHER EQUIPMENT. VIKING'S WARRANTY DOES NOT COVER FAILURE DUE TO IMPROPER INSTALLATION, OPERATION OR MAINTENANCE.

THIS INFORMATION MUST BE FULLY READ BEFORE BEGINNING INSTALLATION, OPERATION OR MAINTENANCE OF PUMP AND MUST BE KEPT WITH PUMP. PUMP MUST BE INSTALLED, OPERATED AND MAINTAINED ONLY BY SUITABLY TRAINED AND QUALIFIED PERSONS.

THE FOLLOWING SAFETY INSTRUCTIONS MUST BE FOLLOWED AND ADHERED TO AT ALL TIMES.

Symbol Legend :



**Danger** - Failure to follow the indicated instruction may result in serious injury or death.

**WARNING**

**Warning** - In addition to possible serious injury or death, failure to follow the indicated instruction may cause damage to pump and/or other equipment.



**BEFORE** opening any liquid chamber (pumping chamber, reservoir, relief valve adjusting cap fitting, etc.) be sure that :

- Any pressure in the chamber has been completely vented through the suction or discharge lines or other appropriate openings or connections.
- The pump drive system means (motor, turbine, engine, etc.) has been "locked out" or otherwise been made non-operational so that it cannot be started while work is being done on the pump.
- You know what material the pump has been handling, have obtained a material safety data sheet (MSDS) for the material, and understand and follow all precautions appropriate for the safe handling of the material.

**WARNING**

**INSTALL** pressure gauges/sensors next to the pump suction and discharge connections to monitor pressures.



**WARNING**

**USE** extreme caution when lifting the pump. Suitable lifting devices should be used when appropriate. Lifting eyes installed on the pump must be used **only** to lift the pump, **not** the pump with drive and/or base plate. If the pump is mounted on a base plate, the base plate must be used for all lifting purposes. If slings are used for lifting, they must be safely and securely attached. For weight of the pump alone (which does not include the drive and/or base plate) refer to the Viking Pump product catalog.



**DO NOT** attempt to dismantle a pressure relief valve that has not had the spring pressure relieved or is mounted on a pump that is operating.



**AVOID** contact with hot areas of the pump and/or drive. Certain operating conditions, temperature control devices (jackets, heat-tracing, etc.), improper installation, improper operation, and improper maintenance can all cause high temperatures on the pump and/or drive.



**WARNING**

**THE PUMP** must be provided with pressure protection. This may be provided through a relief valve mounted directly on the pump, an in-line pressure relief valve, a torque limiting device, or a rupture disk. If pump rotation may be reversed during operation, pressure protection must be provided on **both** sides of pump. Relief valve adjusting screw caps must always point towards suction side of the pump. If pump rotation is reversed, position of the relief valve must be changed. Pressure relief valves cannot be used to control pump flow or regulate discharge pressure. For additional information, refer to Viking Pump's Technical Service Manual TSM 000 and Engineering Service Bulletin ESB-31.



**WARNING**

**THE PUMP** must be installed in a manner that allows safe access for routine maintenance and for inspection during operation to check for leakage and monitor pump operation.



**BEFORE** operating the pump, be sure all drive guards are in place.



**DO NOT** operate pump if the suction or discharge piping is not connected.



**DO NOT** place fingers into the pumping chamber or its connection ports or into any part of the drive train if there is **any possibility** of the pump shafts being rotated.



**WARNING**

**DO NOT** exceed the pumps rated pressure, speed, and temperature, or change the system/duty parameters from those the pump was originally supplied, without confirming its suitability for the new service.



**WARNING**

**BEFORE** operating the pump, be sure that:

- It is clean and free from debris
- all valves in the suction and discharge pipelines are fully opened.
- All piping connected to the pump is fully supported and correctly aligned with the pump.
- Pump rotation is correct for the desired direction of flow.

**WARNING**

Appropriate hearing protection devices are utilized as the sound level for the pump may be above 85 dBA under certain operating conditions.

## SPECIAL INFORMATION

### DANGER !

Before opening any Viking pump liquid chamber (pumping chamber, reservoir, relief valve adjusting cap fitting, etc.) Be sure:

1. That any pressure in the chamber has been completely vented through the suction or discharge lines or other appropriate openings or connections.
2. That the driving means (motor, turbine, engine, etc.) has been “locked out” or made non-operational so that it cannot be started while work is being done on pump.
3. That you know what liquid the pump has been handling and the precautions necessary to safely handle the liquid. Obtain a material safety data sheet (MSDS) for the liquid to be sure these precautions are understood.

Failure to follow above listed precautionary measures may result in serious injury or death.

**ROTATION:** The KE –QS 4195 series are directional due to the loading groove in the head. This series is designed to operate in **CLOCKWISE** rotation only. Shaft rotation and head design determines which port is suction and which is discharge. Suction port is where pumping elements (gear teeth) come out of mesh. An arrow on the head of the pump indicates rotation and direction of flow.

#### PRESSURE RELIEF VALVES:

1. Viking pumps are positive displacement pumps and must be provided with some sort of pressure protection. This may be a relief valve mounted directly on the pump, an inline pressure relief valve, a torque limiting device or a rupture disk.
2. The relief valve adjusting screw cap must always point towards the suction side of the pump. See **Figure 2**.
3. Pressure relief valves should not be used to control flow or regulate discharge pressure.

RELIEF VALVE  
ADJUSTING  
SCREW CAP

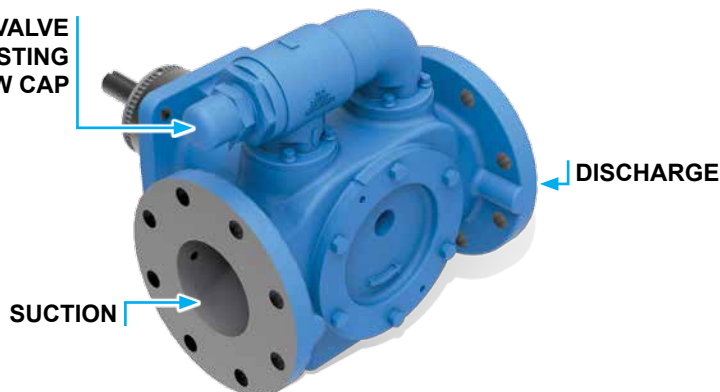

FIGURE 2

For additional information on pressure relief valves, refer to **Technical Service Manual TSM 000 and Engineering Service Bulletin ESB-31**.

#### SPECIAL MECHANICAL SEALS:

This bulletin illustrates the mechanical seal which is standard in the catalog pump.

## MAINTENANCE

Series 4195 pumps are designed for long, trouble-free service life under a wide variety of application conditions with a minimum of maintenance. The points listed below will help provide long service life.

**CLEANING PUMP:** Keep the pump as clean as possible. This will facilitate inspection, adjustment and repair work and help prevent overlooking a dirt covered grease fitting.

**STORAGE:** If the pump is to be stored, or not used for six months or more, the pump must be drained and a light coat of non-detergent SAE 30 weight oil must be applied to all internal pump parts. Apply grease to the pump shaft extension. Viking suggests rotating pump shaft by hand one complete revolution every 30 days to circulate the oil.

**SUGGESTED REPAIR TOOLS:** The following tools must be available to properly repair Series 4195 pumps. These tools are in addition to standard mechanics' tools such as open end wrenches, pliers, screw drivers, etc. Most of the items can be obtained from an industrial supply house.

1. Soft Headed hammer
2. Allen wrenches (set screws & special mechanical seals)
3. Mechanical Seal Installation Sleeve  
2-751-003-730 for 1.44 inch seal; KE-KKE 4195  
2-751-012-630 for 1.63 inch seal; LQE-LSE 4195  
2-751-005-630 for 2.44 inch seal; Q-QS 4195
4. Bearing Locknut Spanner Wrench – 2-810-043-375
5. Spanner Wrench, adjustable pin type for use on bearing housing end cap. – 2-810-008-375
6. Brass bar
7. Arbor press
8. Standard 5/16” 12 point socket
9. Anti-fretting agent (SKF LGAF 3E)

# DISASSEMBLY

## DANGER !

Before opening any Viking pump liquid chamber (pumping chamber, reservoir, relief valve adjusting cap fitting, etc.) Be sure:

1. That any pressure in the chamber has been completely vented through the suction or discharge lines or other appropriate openings or connections.
2. That the driving means (motor, turbine, engine, etc.) has been "locked out" or made non-operational so that it cannot be started while work is being done on pump.
3. That you know what liquid the pump has been handling and the precautions necessary to safely handle the liquid. Obtain a material safety data sheet (MSDS) for the liquid to be sure these precautions are understood.

Failure to follow above listed precautionary measures may result in serious injury or death.

1. Refer to **Figures 4 & 5** for model to be disassembled and name of parts. All 4195 models referenced in this TSM are disassembled and assembled in the same manner.
2. Mark the head and casing before disassembly to insure proper reassembly.
3. Remove the head capscrews.
4. Tilt the top of the head back when removing to prevent the idler from falling off the idler pin.
5. Remove the idler and bushing assembly. If the idler bushing needs replacing, see "**Installation of Carbon Graphite Bushings**," page 8.
6. Insert a brass bar or piece of hardwood in the port opening and between the rotor teeth to keep the shaft from turning. Turn the locknut counterclockwise and remove locknut. See **Figure 6 or 7**, page 6.
7. Bend up tang of lockwasher and with a spanner wrench remove locknut and lockwasher from shaft. See **Figure 6 or 7**, page 6.
8. Loosen the two setscrews in the face of the bearing housing and turn the thrust bearing assembly counterclockwise and remove from casing. See **Figure 6 or 7**, page 6.
9. Remove the bearing spacer from the shaft.
10. Remove the brass bar or piece of hardwood from the port opening.

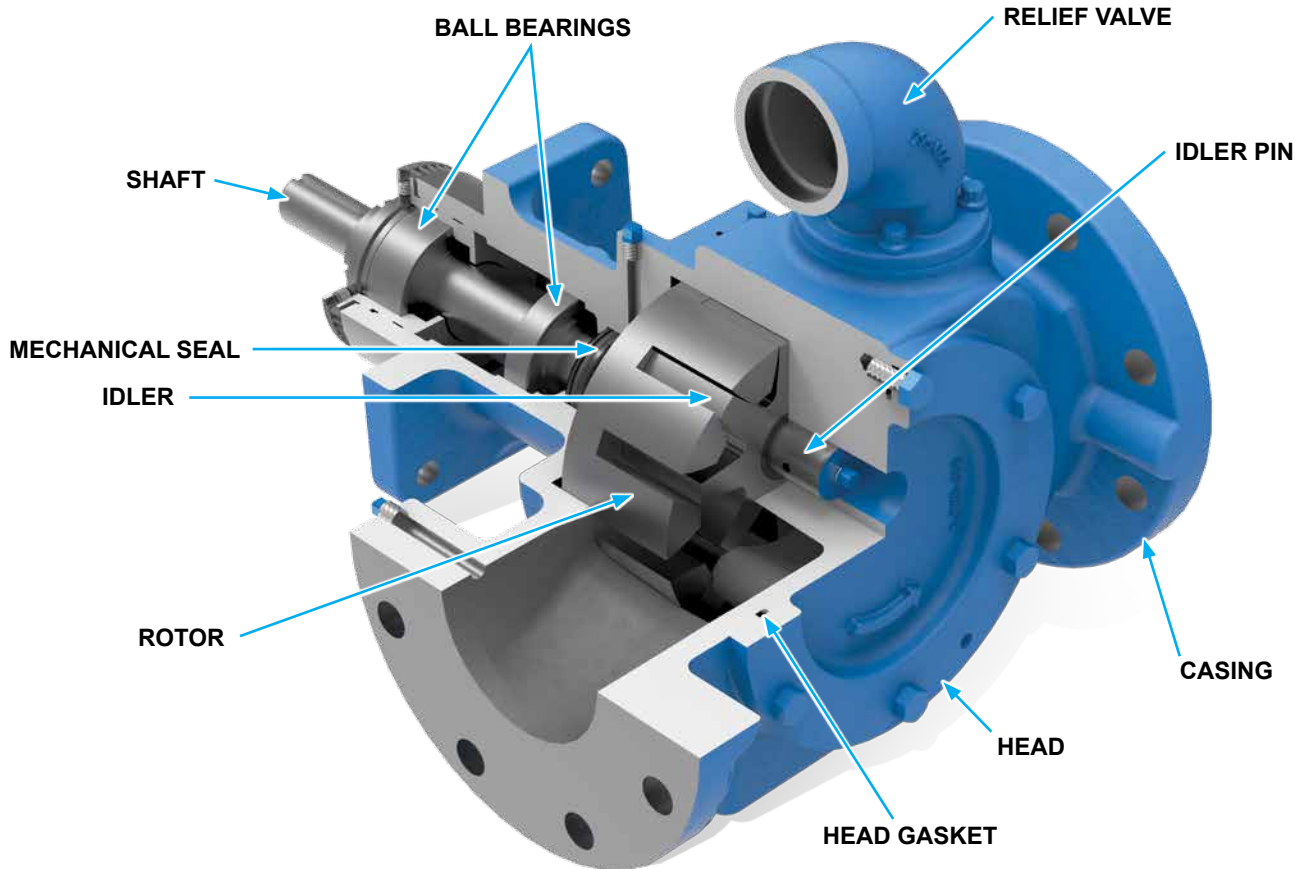
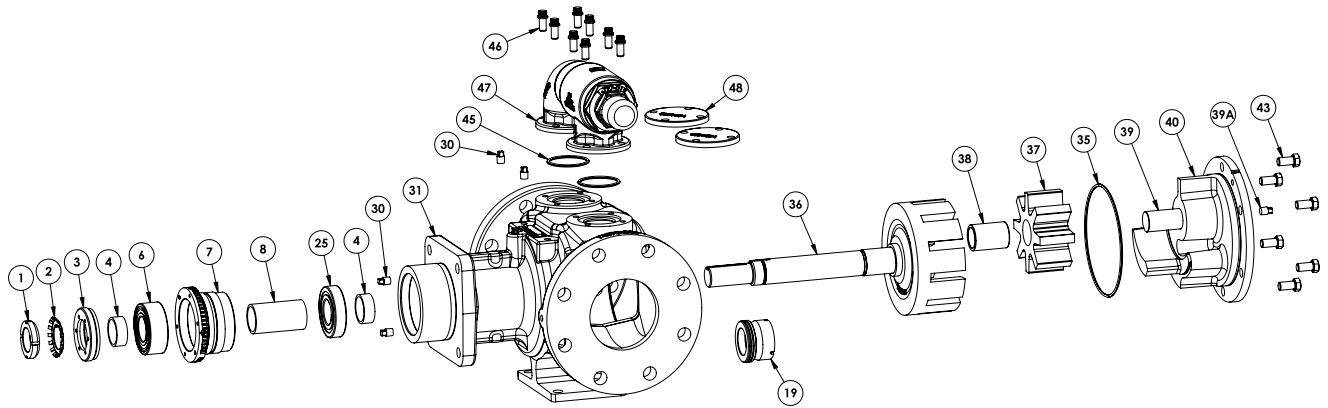
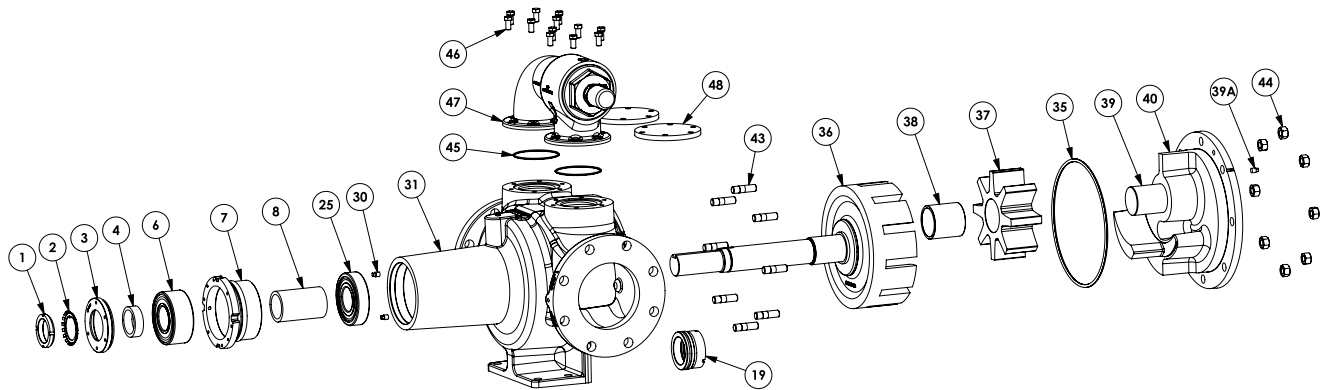

FIGURE 3  
CUTAWAY FOR MODELS KE, KKE, LQE, & LSE 4195



**FIGURE 4 - EXPLODED VIEW FOR MODELS KE, KKE, LQE, LSE 4195**

ITEM	NAME OF PART	ITEM	NAME OF PART	ITEM	NAME OF PART
1	Locknut	25	Ball Bearing (Inner)	40	Head and Idler Pin Assembly
2	Lockwasher	31	Casing	43	Capscrews for Head
3	End Cap for Bearing Housing	35	Head O-Ring	45	Relief Valve O-Rings
4	Bearing Spacer Collar	36	Rotor and Shaft Assembly	46	Capscrews for Relief Valve
6	Ball Bearing (Outer)	37	Idler and Bushing Assembly	47	Relief Valve
7	Bearing Housing	38	Idler Bushing	48	Relief Valve Covers
8	Bearing Spacer	39	Idler Pin		
19	Mechanical Seal	39A	Pipe Plug		



**FIGURE 5 - EXPLODED VIEW FOR MODELS Q AND QS 4195**

ITEM	NAME OF PART	ITEM	NAME OF PART	ITEM	NAME OF PART
1	Locknut	25	Ball Bearing (Inner)	40	Head and Idler Pin Assembly
2	Lockwasher	31	Casing	43	Studs for Head
3	End Cap for Bearing Housing	35	Head O-Ring	44	Nuts for Head
4	Bearing Spacer Collar	36	Rotor and Shaft Assembly	45	Relief Valve O-Rings
6	Ball Bearing (Outer)	37	Idler and Bushing Assembly	46	Capscrews for Relief Valve
7	Bearing Housing	38	Idler Bushing	47	Relief Valve
8	Bearing Spacer	39	Idler Pin	48	Relief Valve Covers
19	Mechanical Seal	39A	Pipe Plug		



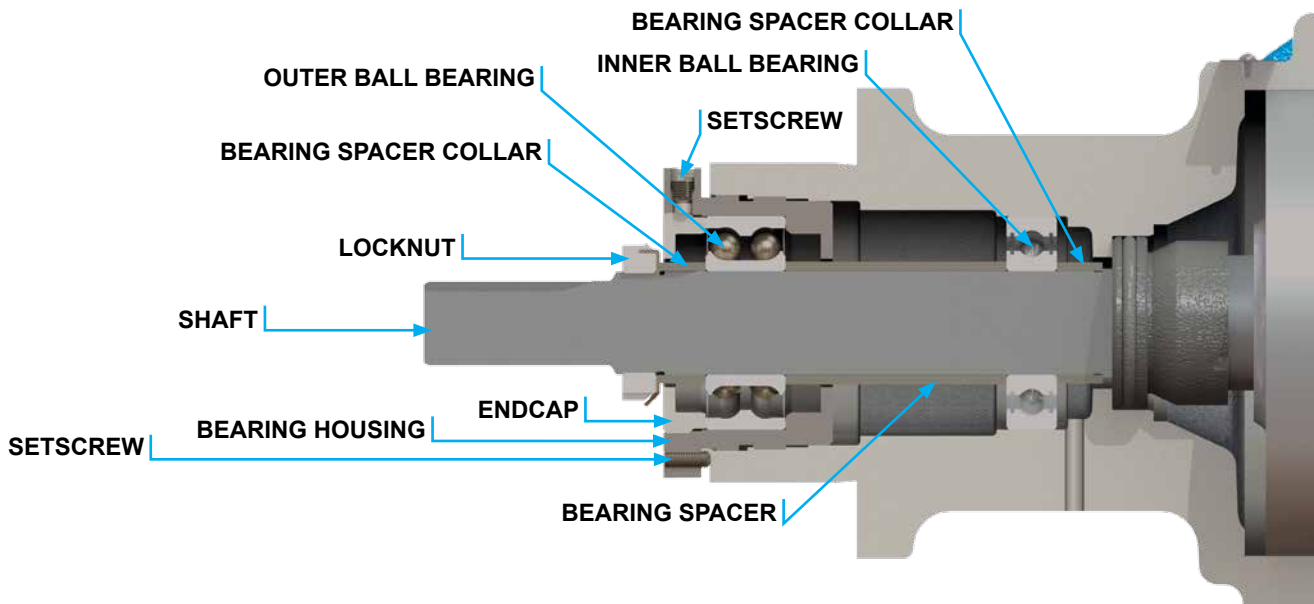

FIGURE 6 - THRUST BEARING ASSEMBLY KE, KKE, LQE, LSE SIZES

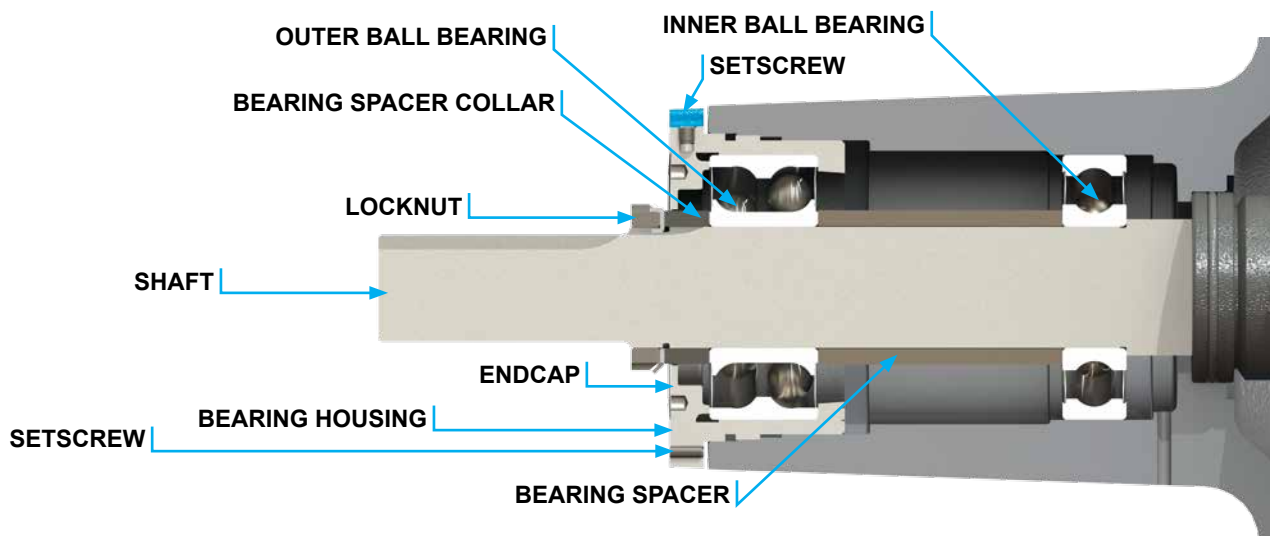

FIGURE 7 - THRUST BEARING ASSEMBLY Q AND QS SIZES

11. The rotor and shaft can now be removed by tapping on the end of the shaft with a soft lead hammer or, if using a regular hammer, use a piece of hardwood between the shaft and hammer. The rotary member of the seal will come out with the rotor and shaft.
11. Remove the mechanical seal rotary member from the rotor and shaft assembly
12. **KE, KKE, LQE, LSE:** Remove the inner single row ball bearing and bearing spacer collar from the casing. See **Figure 6**.  
**Q, QS:** Remove the single row ball bearing from the casing. See **Figure 7**.
13. Remove the seal seat or stationary part of the seal from the casing.
14. Disassemble the thrust bearing assembly.

Loosen the two setscrews in the flange outside diameter. Rotate the end cap counterclockwise and remove. Remove the ball bearing. See **Figure 7**.

The casing should be examined for wear, particularly in the area between the ports. All parts should be checked for wear before the pump is put together.

When making major repairs, such as replacing a rotor and shaft; it is advisable to also install a new mechanical seal, head and idler pin, idler and bushing. See **“Installation of Carbon Graphite Bushings,”** page 8.

Clean all parts thoroughly and examine for wear or damage. Check the ball bearings, bushing and idler pin and replace if necessary. Check all other parts for nicks, burrs, excessive wear and replace if necessary.

Check the bearings for roughness. Roughness can be determined by turning the outer race by hand. Replace the bearings if they have roughness.

Be sure the shaft is free from nicks, burrs and foreign particles that might damage the mechanical seal. Scratches on the shaft in seal area will provide leakage paths under the mechanical seal. Use a fine emery cloth to remove scratches or sharp edges.

# ASSEMBLY

## Standard Mechanical Seal

(Synthetic Rubber Bellows Type)

### READ CAREFULLY BEFORE REASSEMBLING PUMP

The seal used in this pump is simple to install and good performance will result if care is taken during installation.

The principle of a mechanical seal is contact between the rotary and stationary members. These parts are lapped to a high finish and their sealing effectiveness depends on complete contact.

Never touch the sealing faces with anything except clean hands or clean cloth. Minute particles can scratch the seal faces and cause leakage.

1. Coat the idler pin with non-detergent SAE 30 weight oil and place idler and bushing on idler pin in the head. If replacing a carbon graphite bushing, refer to **"Installation of Carbon Graphite Bushings,"** page 8.
2. Clean the rotor hub and casing seal housing bore. Make sure both are free from dirt and grit. Coat the outer diameter of seal seat and inner diameter of seal housing bore with Molykote 55 or compatible O-ring lubricant.
3. Start the seal seat in the seal housing bore. If force is necessary protect the seal face with a clean cardboard disc and gently tap it in place with a piece of wood. Be sure the seal seat is completely seated in the bore.
4. Place a tapered installation sleeve on the shaft, see **Figure 8**. Coat the rotor shaft, tapered installation sleeve and inner diameter of the mechanical seal rotary member with a generous amount of Molykote 55 or compatible O-ring lubricant.
5. Slide the rotary member, lapped contact surface facing away from the rotor, over installation sleeve on shaft until just contacting the back of the rotor. See **Figure 9**. Remove the installation sleeve. **Tighten the setscrews evenly to 90 in-lbs.**
6. Install the rotor and shaft into the casing, slowly pushing until the ends of the rotor teeth are just below the face of the casing. Take care not to damage the seal seat.
7. Place the O-ring on the head and install the head and idler assembly on pump. The pump head and casing were marked before disassembly to insure proper reassembly. If not, be sure the idler pin, which is offset in the pump head, is positioned up and equal distance between port connections to allow for proper flow of liquid through the pump.
8. Tighten the head capscrews evenly.
9. If the pump was equipped with a relief valve and was removed during disassembly, install on the casing with new O-rings or gaskets. The relief valve adjusting screw cap must always point towards the suction port. Refer to **Figure 2**, page 3. For relief valve repair or adjustments, see **"Pressure Relief Valve Instructions,"** page 8.
10. Coat the inner diameter of the bearings, bearing spacer, and bearing spacer collar with an anti-fretting agent.
11. **KE, KKE, LQE, LSE:** Install the bearing spacer collar over the shaft into the bore. See **Figure 6**. The Q and QS do not contain a bearing spacer collar.

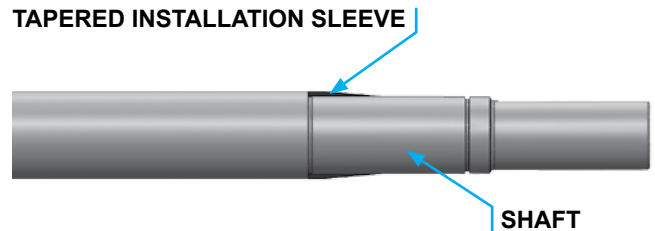

FIGURE 8

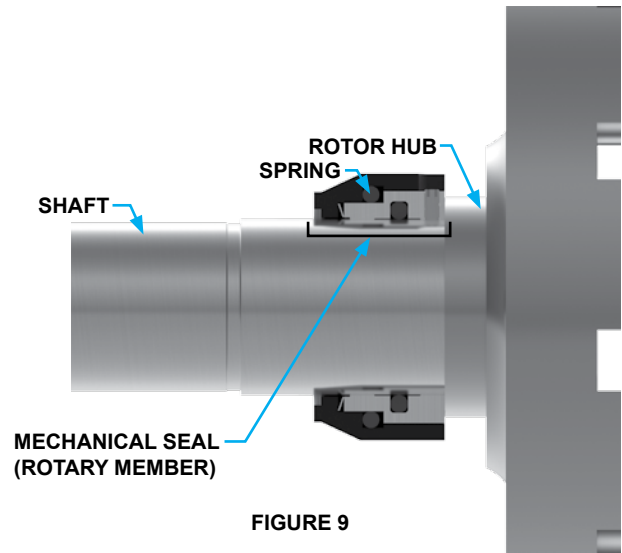

FIGURE 9

12. Pumps use "Sealed for Life" bearings that have seals on both sides. The bearings can be installed either side first and do not need to be packed with grease.
13. Install the bearing into the bore. Tap the inner race with a brass bar and lead hammer to position bearing.
14. Install the bearing spacer over the shaft and against the single row ball bearing. See **Figure 8**.
15. Install the ball bearing into the bearing housing. Install the bearing spacer collar in the end cap and turn the end cap into the bearing housing until tight against the bearing. Lock in place with two set screws in the flange of the bearing housing. See **Figure 7**.
16. Start the bearing housing assembly into casing. Turn by hand until tight. Put lockwasher and locknut on shaft. Insert length of hardwood or brass through port opening between rotor teeth to keep shaft from turning. Tighten locknut to 100-130 ft.- lbs. (KE, KKE), or 120 - 150 ft. - lbs. (LQE, LSE), or 150 - 170 ft. - lbs. (Q, QS). Bend one tang of lockwasher into slot of locknut. If tang does not line up with slot, tighten locknut until it does. Failure to tighten locknut or engage lockwasher tang could result in early bearing failure and cause damage to pump.
17. Remove length of hardwood or brass from port opening.
18. Adjust pump end clearance, refer to **"Thrust Bearing Adjustment"**, page 8.

## DANGER !

Before starting pump, be sure all drive equipment guards are in place.

Failure to properly mount guards may result in serious injury or death.

## THRUST BEARING ADJUSTMENT

See Figures 6 and 7, page 6.

1. Loosen the two set screws in the outer face of the bearing housing and turn this thrust bearing assembly clockwise until it can no longer be turned by hand. Back off counter-clockwise until the rotor shaft can be turned by hand with a slight noticeable drag. If the shaft cannot be rotated freely, turn the thrust bearing assembly counterclockwise until the shaft can be turned easily.
2. For standard end clearance, back off the thrust bearing assembly the required length measured on the outside diameter of the bearing housing. See **Table 1** below.
3. After the adjustment is made, tighten the two setscrews in the face of the bearing housing assembly to secure the position. Your pump is now set with standard end clearances and locked.

PUMP SIZE	DISTANCE IN INCHES ON O.D. OF BEARING HOUSING	STANDARD END CLEARANCE
KE, KKE	5/8"	.005"
LQE, LSE	5/8"	.005"
Q, QS	11/16"	.010"

TABLE 1

## INSTALLATION OF CARBON GRAPHITE BUSHINGS

When installing the carbon graphite bushings, extreme care must be taken to prevent breaking. Carbon graphite is a brittle material and is easily cracked. If cracked, the bushing will quickly disintegrate. Using a lubricant and adding a chamfer on the bushing and the mating part will help in installation. The additional precautions listed below must be followed for proper installation:

1. A press must be used for installation.
2. Be certain the bushing is started straight.
3. Do not stop pressing the operation until the bushing is in the proper position, as starting and stopping may result in a cracked bushing.
4. Check the bushing for cracks after installation.

## PRESSURE RELIEF VALVE INSTRUCTIONS

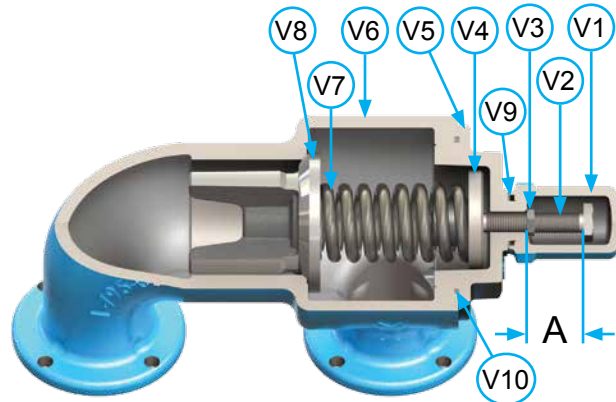

FIGURE 10  
RELIEF VALVE - ALL SIZES

### VALVE - LIST OF PARTS

V1. Valve Cap	V6. Valve Body
V2. Adjusting Screw	V7. Valve Spring
V3. Lock Nut	V8. Poppet
V4. Spring Guide	V9. Cap Gasket
V5. Bonnet	V10. Bonnet Gasket

## DISASSEMBLY

### DANGER !

Before opening any Viking pump liquid chamber (pumping chamber, reservoir, relief valve adjusting cap fitting, etc.) Be sure:

1. That any pressure in the chamber has been completely vented through the suction or discharge lines or other appropriate openings or connections.
2. That the driving means (motor, turbine, engine, etc.) has been "locked out" or made non-operational so that it cannot be started while work is being done on pump.
3. That you know what liquid the pump has been handling and the precautions necessary to safely handle the liquid. Obtain a material safety data sheet (MSDS) for the liquid to be sure these precautions are understood.

Failure to follow above listed precautionary measures may result in serious injury or death.



Mark the valve and head before disassembly to ensure proper reassembly.

1. Remove the valve cap.
2. Measure and record the length of extension of the adjusting screw. Refer to "A" on **Figure 10**.
3. Loosen the locknut and back out the adjusting screw until spring pressure is released.
4. Remove the bonnet, spring guide, spring and poppet from the valve body. Clean and inspect all parts for wear or damage and replace as necessary.

## ASSEMBLY

Reverse the procedures outlined under "Disassembly." If the valve is removed for repairs, be sure to replace in the same position. The relief valve adjusting screw cap must always point towards suction side of the pump. If the pump rotation is reversed, remove the relief valve and turn end for end. Refer to **Figure 4**, page 4.

### **DANGER !**

**Before starting pump, be sure all drive equipment guards are in place.**

**Failure to properly mount guards may result in serious injury or death.**

## PRESSURE ADJUSTMENT

If a new spring is installed or if the pressure setting of the pressure relief valve is to be changed from that which the factory has set, the following instructions must be carefully followed.

1. Carefully remove the valve cap which covers the adjusting screw.  
Loosen the locknut which locks the adjusting screw so the pressure setting will not change during operation of the pump.
2. Install a pressure gauge in the discharge line for actual adjustment operation.
3. Turn the adjusting screw in to increase the pressure and out to decrease the pressure.
4. With discharge line closed at a point beyond pressure gauge, the gauge will show the maximum pressure the valve will allow while the pump is in operation.

## IMPORTANT

When ordering parts for the pressure relief valve, always give the model number and serial number of the pump as it appears on the nameplate and the name of the part wanted. When ordering springs, be sure to give the pressure setting desired.

**VIKING  
PUMP**

# TECHNICAL SERVICE MANUAL

HEAVY-DUTY PUMPS

SERIES 4195

SIZES KE, KKE, LQE, LSE, Q, & QS

SECTION	TSM 144.1
PAGE	10 OF 10
ISSUE	B

**VIKING  
PUMP**

**IDEX**

## WARRANTY

Viking warrants all products manufactured by it to be free from defects in workmanship or material for a period of one (1) year from date of startup, provided that in no event shall this warranty extend more than eighteen (18) months from the date of shipment from Viking. The warranty period for Universal Seal series pumps ONLY is three (3) years from date of startup, provided that in no event shall this warranty extend more than forty-two (42) months from the date of shipment from Viking.

UNDER NO CIRCUMSTANCES SHALL VIKING BE LIABLE UNDER THIS WARRANTY OR OTHERWISE FOR SPECIAL, INCIDENTAL, INDIRECT, CONSEQUENTIAL OR PUNITIVE DAMAGES OF ANY KIND, INCLUDING, BUT NOT LIMITED TO, LOST OR UNREALIZED SALES, REVENUES, PROFITS, INCOME, COST SAVINGS OR BUSINESS, LOST OR UNREALIZED CONTRACTS, LOSS OF GOODWILL, DAMAGE TO REPUTATION, LOSS OF PROPERTY, LOSS OF INFORMATION OR DATA, LOSS OF PRODUCTION, DOWNTIME, OR INCREASED COSTS, IN CONNECTION WITH ANY PRODUCT, EVEN IF VIKING HAS BEEN ADVISED OR PLACED ON NOTICE OF THE POSSIBILITY OF SUCH DAMAGES AND NOTWITHSTANDING THE FAILURE OF ANY ESSENTIAL PURPOSE OF ANY PRODUCT.

THIS WARRANTY IS AND SHALL BE VIKING'S SOLE AND EXCLUSIVE WARRANTY AND SHALL BE IN LIEU OF ALL OTHER WARRANTIES, EXPRESS OR IMPLIED, INCLUDING, BUT NOT LIMITED TO, ALL WARRANTIES OF MERCHANTABILITY, FITNESS FOR A PARTICULAR PURPOSE AND NON-INFRINGEMENT ALL OF WHICH OTHER WARRANTIES ARE EXPRESSLY EXCLUDED.

See complete warranty at [www.vikingpump.com](http://www.vikingpump.com).

